

# 1.25" Single Horizontal Cable Management Ring



## Package Includes:

- A. 1.25" Single Horizontal Cable Management Ring, **1 Piece**
- B. #12-24 x 5/8" Pan Head, Pilot Point Machine Screw, **2 Pieces**

## Features and Benefits

- Provides flexibility for front and back cable management with a neat and clean appearance
- Suitable for distribution racks, wall mount racks, and wall mount brackets
- Used with ICCMS distribution racks, ICCMSWMR wall mount racks, ICCMSSFR wall mount swing frame, ICCMSVHB wall mount vertical hinged brackets, and ICCMSHB wall mount hinged bracket

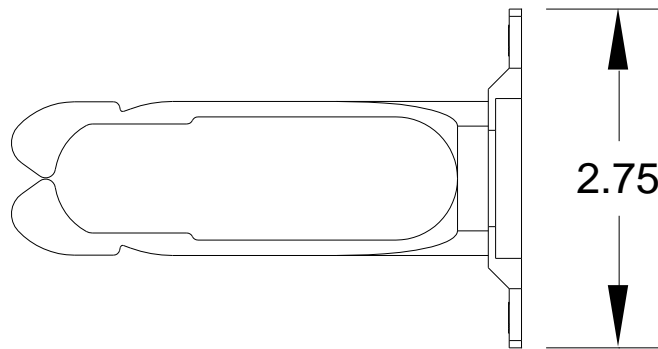
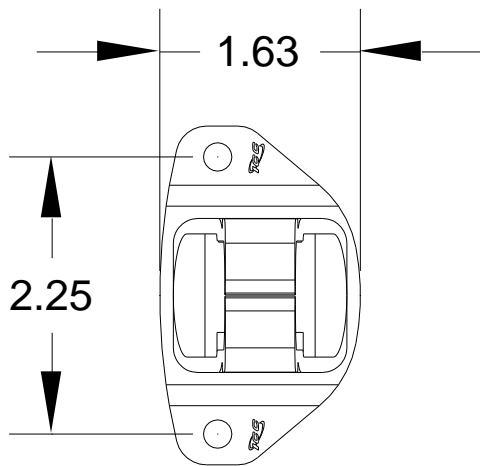
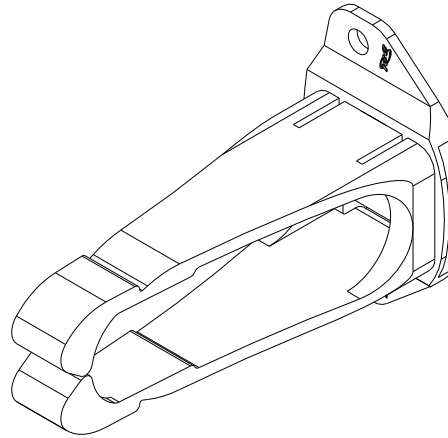
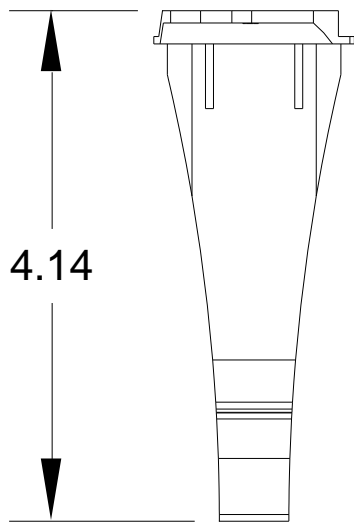

**NOTE: UNLESS OTHERWISE SPECIFIED**

1. Material: High Impact ABS, UL 94V-0
2. Color: Black